

Technical specification

aura 406 EG | bt80-1 provisional



Design:

170 kW el.
400 V / 50 Hz
natural gas
Hi = 10.25 kWh/Nm³
NO_x < 50 mg/Nm³
Exhaust cooling to 100 °C

1 Genset	3
1.1 Engine	3
1.2 Generator (utility planning data)	4
2 Mixture composition	4
2.1 Combustion air	4
2.2 Fuel	5
3 Integrated heat extraction	5
3.1 Heating circuit	5
3.2 Engine circuit	5
4. Exhaust system	6
5 Ventilation	6
6 Operating fluids	6
7 Electronics and software	6
8 Interfaces	7
8.1 Dimensions and weights	7
8.2 Water / gas transfer points	8
8.3 Electrical connections / utility interface	8
8.4 Data interfaces	8
9 Technical boundary conditions	9

Subject to technical changes!

Note: Figure on cover page may differ

1 Genset

	50 %	75 %	100 %	Load
Electrical power	85	128	170	kW ⁽⁵⁾
Recoverable thermal output	163	209	263	kW ⁽²⁾
Energy input	258	353	456	kW ⁽¹⁾
Efficiencies electrical	32.9	36.2	37.3	% ⁽¹⁾
Efficiencies thermal	62.9	59.2	57.7	% ^{(1), (2)}
Efficiencies total (el. + th.)	95.8	95.4	95.0	% ^{(1), (2)}
CHP coefficient	0.52	0.61	0.65	^{(1), (2)}

Exhaust emissions

	with catalytic converter *	without exhaust aftertreatment	
NOx	< 50	< 6500	mg/Nm ³ ^{(4), (6)}
CO	< 100	< 4500	mg/Nm ³ ^{(4), (6)}
HCHO	< 40	k.A	mg/Nm ³ ^{(4), (6)}

1.1 Engine

Engine manufacturer	2G		
Engine type	aura 406 EG bt80		
Type / No. of cylinders	row / 6		
Operating method	4-stroke		
Combustion process	$\lambda = 1$		
Engine displacement	11900	ccm	
Bore / Stroke	130 / 150	mm	
RPM	1500	1/min	
ISO standard power (mech.)	178	kW	
compression ratio	12.5 : 1		
average effective pressure	12.0	bar	
average piston speed	7.5	m/s	
body of balance wheel	SAE 1		
Direction of rotation (based on balance wheel)	left		
tooth rim with number of teeth	167		
Engine dead weight	1125	kg	
Engine surface noise **	102.8	dB(A) ⁽⁷⁾	
Engine surface noise with sound reducing encapsulation (optional) ***	70	dB(A) ⁽⁷⁾	

* With appropriate catalyst configuration!

** Total sound power level at full engine load in accordance with DIN EN ISO 3746

*** Average sound pressure level under open area conditions at distance of 1 m in accordance with DIN 45635

An increased noise load must be taken into account with fresh air intake from the installation room.

1.2 Generator (utility planning data)

Manufacturer	Leroy Somer	
Type	LSA 46.3 M7 / 4p	
Generator type	Synchronous, directly coupled	
Voltage regulator (AVR)	D510C	
Rated speed	1500	1/min
Frequency	50	Hz
mechanical fuel shutoff	178	kW
Effective electrical power	170	kW
Apparent electrical power (cos φ 1.0 / cos φ 0.9)	170 / 189	kVA
Rated generator current (cos φ 1.0 / cos φ 0.9)	245 / 273	A
Rated generator voltage (\pm 10 %)	400	V
Subtransient reactance X"d	9.6	%
Short-circuit current I _k "3	3.54	kA
Power factor cos φ (inductive / capacitive)	0,9 / 0,9	
Generator circuit breaker	400	A
Additional section switch (VDE-AR-N 4105)	400	A
Efficiency (full load) at Cos φ = 1	95.4	%
Mass moment of inertia	3.2	kg · m ²
Ambient air temperature	40	°C
Stator circuit	star	
Protection class	IP 23	
Generator weight	754	kg
Compensation	not available	
Engine startup	not available	

2 Mixture composition

2.1 Combustion air

Combustion air mass flow	565	kg/h
Combustion air volume flow (25 °C, 1013 mbar)	477	m ³ /h

2.2 Fuel

Fuel requirements in accordance with 'TA-004 Gas'

Reference methane number - minimum methane number	80 / 80	
Combustible mass flow	35.7	kg/h ⁽¹⁾
Combustible volume flow	44.5	Nm ³ /h ^{(6), (1)}
Gas pressure at rated load min. *	20	mbar
Gas flow pressure at rated load max. *	70	mbar
Gas regulation line safety pressure	500	mbar

* At the inlet to the gas regulation line

3 Integrated heat extraction

3.1 Heating circuit

Heating water requirements in accordance with 'TA-002 Heating circuit'

Heating water volume flow ($\Delta t = 20$ K)	11.3	m ³ /h
Heating water return temperature (max)	70	°C
Heating water flow temperature (max) **	90	°C ⁽⁸⁾
Safety valve	6	bar
Operating pressure (min.)	1	bar
Internal pressure loss in heating circuit (approx.) *	420	mbar
Pressure reserve ca. *	500	mbar

3.2 Engine circuit

Coolant requirements in accordance with 'TA-001 Coolant'

Coolant heat	162	kW ⁽²⁾
Engine inflow temperature (min.)	80	°C
Engine exit temperature (max.)	88	°C
Balance inflow / exit (max.)	6	K
Recirculated coolant quantity (min.)	27.0	m ³ /h
Total cooling water circulation volume	27.0	m ³ /h
Operating pressure (max.)	2	bar
Operating pressure (min.)	1	bar
Safety valve	3.0	bar
Emergency cooling circuit Pressure reserve ca. (optional) *	250	mbar
Safety temperature limiter	110	°C
Mixture heat high temperature circuit (HT)	5	kW ⁽²⁾
Mixture coolant, inflow temperature high temperature circuit (max.)	80	°C
Mixture coolant recirculated quantity high temperature circuit (min.)	27.0	m ³ /h

* Up to / from module interface

** Heating water supply temperature max. in partial load operation < 90 °C

4. Exhaust system

Exhaust gas temperature downstream of engine	585	°C ⁽³⁾
Exhaust temperature after exhaust heat exchanger	100	°C ⁽³⁾
Exhaust gas heat	96	kW ⁽²⁾
exhaust gas volume flow wet	478	Nm ³ /h ⁽⁶⁾
exhaust gas volume flow dry	394	Nm ³ /h ⁽⁶⁾
exhaust gas mass flow wet	600	kg/h
exhaust gas mass flow dry	528	kg/h
Exhaust back pressure downstream of engine	50	mbar
Pressure reserve approx. *	21	mbar
Exhaust outlet noise **	140	dB ⁽⁷⁾

5 Ventilation

radiant heat of module (approx.)	31	kW
Supply air volume flow min. (at $\Delta t = 15$ K)	6684	m ³ /h

6 Operating fluids

Lubricating oil approvals, see 'TA-003 Lubricating oil'

Lubrication oil consumption (\emptyset / max.)	0.1 / 0.3	g/kWh
Filling capacity lubricant (max.)	40	l
Lubricating oil filling tank fill capacity (optional)	100	l
Lubricating oil volume auxiliary tank (optional)	100	l
Motor circuit coolant fill quantity approx. (module)	138	l
Mixture cooling circuit LT coolant fill quantity approx. (module)	-	l

Coolant approvals, see 'TA-001 Coolant'

7 Electronics and software

Grid protection device	Bachmann GSP	
Grid protection software status	> 13414	
Touchscreen display	10	"
Approval (depending on version)	VDE-AR-N 4105 / VDE-AR-N 4110	
Protection class Control cabinet	IP 54	
Protection class Power switch cabinet	IP 54	
Switch cabinet environmental temperature	0 - 35	°C
Switch cabinet relative air humidity (max.)	65	%

* From module interface (exhaust heat exchanger / catalytic converter in standard version and new condition)

** Total sound power level at full engine load in accordance with DIN 45635-11 Annex A

8 Interfaces

8.1 Dimensions and weights

(Figures may differ)

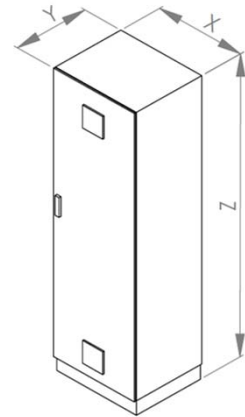
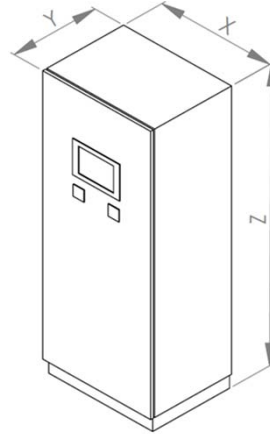
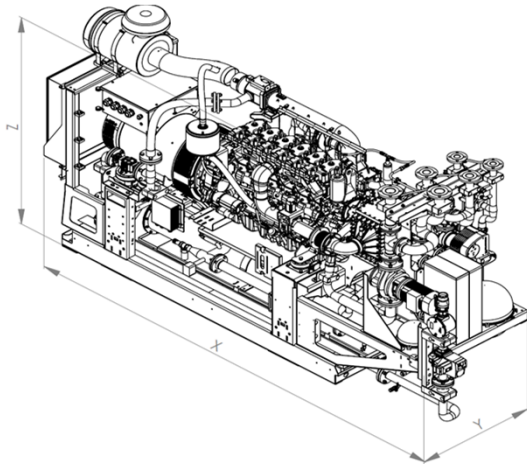

Length Module *	X	3990	mm
Width Module *	Y	1110	mm
Height Module *	Z	2100	mm
Weight Module (without operating fluids)		4460	kg
Weight Module with sound reducing encapsulation (optional)		5485	kg
Powder-coated CHP frame		RAL 6002	
Width Control cabinet	X	800	mm
Depth Control cabinet	Y	600	mm
Height Control cabinet	Z	2000	mm
Weight Control cabinet		200	kg
Control cabinet powder coated		RAL 7035	
Width Power switch cabinet	X	600	mm
Depth Power switch cabinet	Y	500	mm
Height Power switch cabinet	Z	2000	mm
Weight Power switch cabinet		150	kg
Power switch cabinet powder coated		RAL 7035	

*

8.2 Water / gas transfer points

Interfaces Gas	40 / 10	DN / PN
Interfaces Exhaust	150 / 10	DN / PN
Interfaces Heating circuit	50 / 16	DN / PN
Interfaces Emergency cooling circuit	65 / 16	DN / PN

8.3 Electrical connections / utility interface

Grid connection with pre-fuse (customer-provided)	400 V / 50 Hz	
Grid system	TN-S	
Short-circuit proof Icc (max.)	50	kA

8.4 Data interfaces

Remote maintenance access (optional) *	DSL / UMTS (SIM)
Interfaces / Data interfaces (optional):	<ul style="list-style-type: none"> - Profibus DP - Profinet IO - Modbus RTU - Modbus TCP - Ethernet IP - Hardware signals
Access virtual power plant (optional)	Possible after technical clarification (bus or hardware signals)

* Access for remote maintenance must be provided by the customer

9 Technical boundary conditions

Unless otherwise specified, all data is based on full engine load with the respective indicated media temperatures and subject to technical improvements. The generator output measured at the generator terminals serves as the basis for the delivered electrical power. All power and efficiency specifications are gross specifications. The fuel gas quality must conform to the specifications of 'TA-004 Gas'. The operating fluids and plant system layout must conform to the 'Technical instructions' of 2G.

- (1) Performance conditions in accordance with DIN ISO 3046. Tolerance for specific fuel use amounts to + 5% of nominal performance. Efficiency specifications are based on an engine in new condition. An abatement in efficiency over the service life is reduced with observance of the maintenance requirements.
- (2) The tolerance for usable heat output is +/- 8 % under normal load.
- (3) Data according to new condition.
The tolerance for the exhaust temperature is +/- 8 %.
- (4) Corresponding to a residual oxygen concentration in the exhaust of 5 %
- (5) Electrical generator terminal power at $\cos \varphi = 1$.
- (6) Volume specifications for normal status:

Pressure	1013 mbar
Temperature	0 °C
- (7) Standard deviation of reproducibility 4 dB in accordance with DIN EN ISO 3746
- (8) The tolerance for the Heating water flow temperature is +/- 1 °C.

Power specifications in this document relate to standard reference conditions.

Standard reference conditions in accordance with DIN ISO 3046-1:

Air pressure	1000 mbar
Air temperature	25 °C
Relative air humidity	30 %

Power reduction

Power reduction due to installation at altitude > 100m a.s.l. and/or air suction temperature > 25°C shall be determined specifically for each project according "TI-049 Load reduction".